

2.3. POWDER AND RELATED TECHNIQUES: X-RAY TECHNIQUES

setting). If the camera is placed so that the rays from the monochromator are along the camera diameter, the angular range is the same on both sides of the 0° point (symmetric setting) and the usable range is about $60^\circ 2\theta$. The sharpest lines are obtained when the rays are nearly normal to the film. The lines are broadened by inclination of the rays to the film, axial divergence, and specimen thickness. The camera can also be used with the specimen in reflection so that it becomes a Seemann-Bohlin camera with only the back reflections accessible [Fig. 2.3.4.1(d)]. Hofmann & Jagodzinski (1955) designed a double camera in a single body that can record transmission and reflection patterns on separate films.

de Wolff (1948) described a novel Guinier-type camera that can simultaneously record up to four patterns of different specimens on one film with a single monochromator and long fine-focus X-ray tube. The patterns are separated by horizontal partitions. There are some differences in the line widths in the top and bottom patterns. Malmros & Werner (1973) developed an automated film-measuring densitometer to improve the precision in measuring the Guinier films; see also Sonneveld & Visser (1975).

2.3.4.3. Miscellaneous camera types

The symmetrical back-reflection camera, Fig. 2.3.4.1(e), is mainly used for lattice-parameter and solid-solution studies because the high reflection angles can be recorded. The specimen can be mounted on a curved holder matching the film curvature to obtain sharp lines and is oscillated during exposure.

The flat-plate camera, Fig. 2.3.4.1(f), can be used for forward- or back-reflection. The angular range is small and varies inversely with the specimen-to-film distance. Polaroid film is frequently used. The same method is used for Laue photographs, usually in back-reflection with a goniometer to orient the crystal. The method is often used for fibre and polymer specimens because the entire cone can be recorded (Alexander, 1969).

The Gandolfi (1967) camera produces a powder-like pattern from a tiny single crystal by simultaneous rotation of the crystal around two inclined axes. It is often made as a modification to the cylindrical camera. The crystal may be very small but the pattern is greatly improved by using several crystals. The smoothness of the lines depends on the chance orientation of the crystal with respect to the rotation axes, and the multiplicity of the reflection. The centring of the specimen and the rotation axes must be done precisely. Anderson, Zolensky, Smith, Freeborn & Scheetz (1981) obtained patterns routinely from $5\ \mu\text{m}$ particles in 2–4 d exposure at 40 keV, 20 mA in an evacuated camera; see also Sussieck-Fornefeld & Schmetzer (1987) and Rendle (1983). A high-brilliance microfocus X-ray tube can greatly increase the intensity.

Another type of camera for the same purpose was developed by Parrish & Vajda (1971). The small crystal is mounted on a glass fibre at the end of a vertical shaft that rotates continuously and simultaneously scans about 90° . The film is mounted in a half-cylinder with about 20 mm radius. A microscope is used for precise alignment and centring.

A camera with a wide film cassette has been used for high-temperature diffraction patterns. The cassette can be translated synchronously with the change in temperature, or held in fixed positions during exposure at selected temperatures. The advantage is that all the patterns are recorded on a single film showing the phase changes and thermal expansion as a function of temperature. A Weissenberg camera can be adapted for this purpose.

2.3.5. Generation, modifications, and measurement of X-ray spectra

This section covers methods for using X-ray tubes and their operation. The methods of modifying the X-ray spectrum by crystal monochromators, filters, and the detector system apply to powder and single-crystal diffraction. Chapter 4.2 contains a more detailed description of the physics of X-ray sources.

2.3.5.1. X-ray tubes

Vacuum-sealed water-cooled X-ray tubes of the type shown in Fig. 2.3.5.1 are almost exclusively used for powder diffraction. They are installed in either a vertical or a horizontal shield (sometimes called a tower) mounted on the generator, or remotely operated with a long high-voltage cable. The shield is designed to seat the tube cap in the correct position, which allows tube replacement without realigning the instruments. Rotating-anode tubes are becoming more popular. They may be operated at higher currents and, although they require continual pumping, recent designs incorporating a ferromagnetic seal and turbomolecular pump make their use virtually as simple as sealed tubes. For additional background information see Phillips (1985) and Yoshimatsu & Kozaki (1977). End-window tubes with large focal spot have been used mainly for X-ray-fluorescence spectroscopy (Arai, Shoji & Omote, 1986), and fine-point-focus tubes for Kossel diagrams.

The maximum permissible power ratings for sealed water-cooled diffraction tubes are about 60 kV, 60 mA and 3 kW. The rating varies with the focal-spot size, anode element, and the particular manufacturer's specifications. Table 2.3.5.1 lists some typical maximum ratings of sealed and rotating-anode tubes. The brightness or specific loading, expressed as watts per square mm, increases with decreasing focal-spot size. There is a very large increase in brightness in the small microfocus sources that

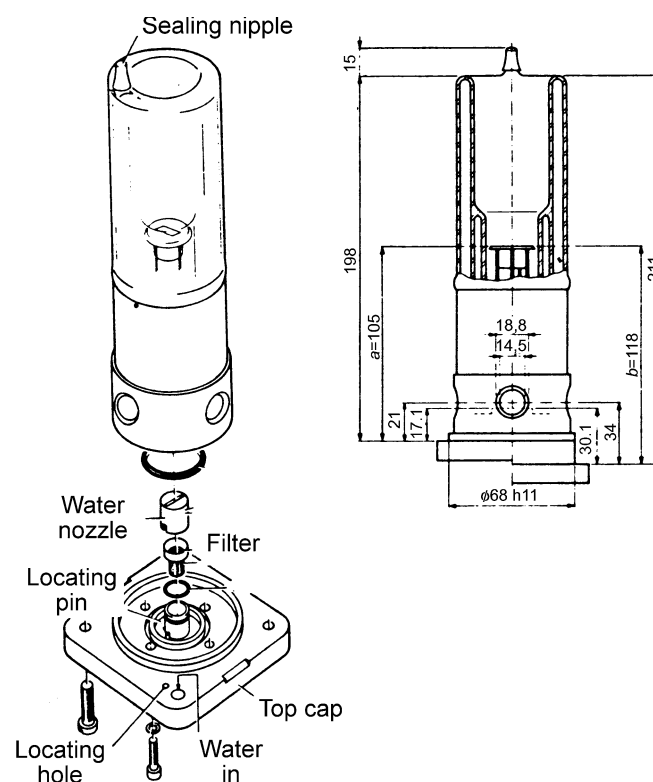

Fig. 2.3.5.1. Sealed X-ray diffraction tube (Philips), dimensions are given in mm. a = 'short' focus, b = 'long' focus.